

# Installing a Merika® water insulation flange with a square cover in a floor drain

According to the construction regulations, floors with drains shall be water insulated unless otherwise instructed by the documents of the building.

Merika water insulation flange is installed in the drain or on a build-up ring so that any water on the water insulation flange can only run to the floor drain. When casting the floor, note the slope reducing effect of the water insulation flange and materials by the drain, which is especially important when using minimum slopes (1:100).

## Preparatory work

Clean the rim of the floor drain to which the water insulation flange is installed (depending on the drain type) with sand paper. The floor to be insulated shall be solid, hard, clean and dust-free. Remove the cement glue or other poorly attached material mechanically from the concrete. Vacuum the floor and seal the inlets.

## Installation of Merika water insulation flange

To insure a proper installation, the water insulation flange must be installed in the drain early before starting any other water insulation work.

The water insulation compound is rolled around the drain. Clean the upper rim of the floor drain or the build-up ring as well as the lip seal in the upper rim. Merika water insulation flange is installed to its place and the drain seal remains in its groove. The water insulation flange is clamped in its place to the drain according to the installation instructions of the water insulation flange. Remove any air bubbles with a trowel.

After the first layer has dried, roll the next layers of the compound on the water insulation flange according to the sealing compound supplier's instructions. After the water insulation work, install the square cover by spreading the adhesive compound evenly around the drain and press the square cover to its place. After this, the floor will be tiled.

The suppliers provide further information if you have any questions.

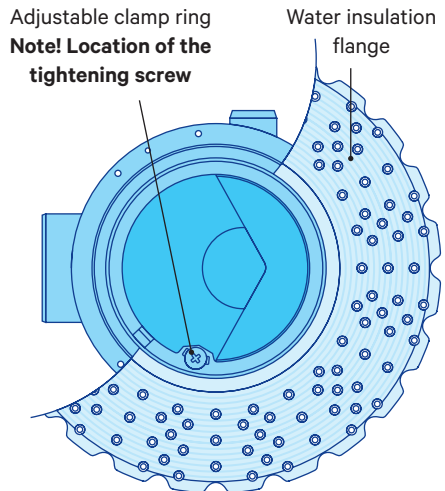

Installing a MERIKA® water insulation flange with a square cover in the floor drain on a concrete floor

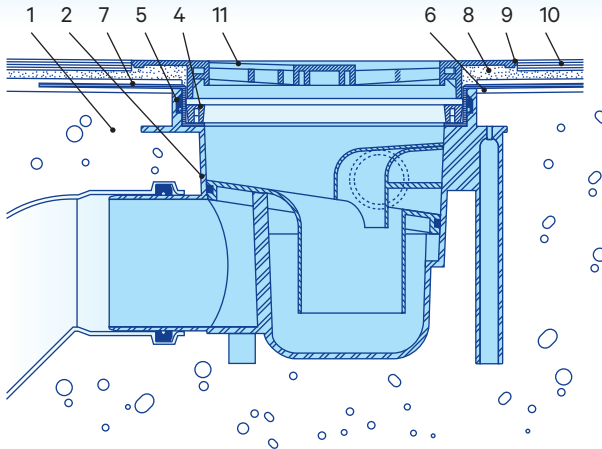

**Description of the numbers:**

1. Concrete
2. Merika® floor drain
3. Merika® build-up ring
4. Clamp ring
5. Flexible V lip seal
6. Water insulation compound
7. Water insulation flange
8. Adhesive compound
9. Grout
10. Tile floor
11. Merika® square cover, plastic or rustproof

Installing a MERIKA® water insulation flange with a square cover in the floor drain with a build-up ring in a thermally insulated concrete floor

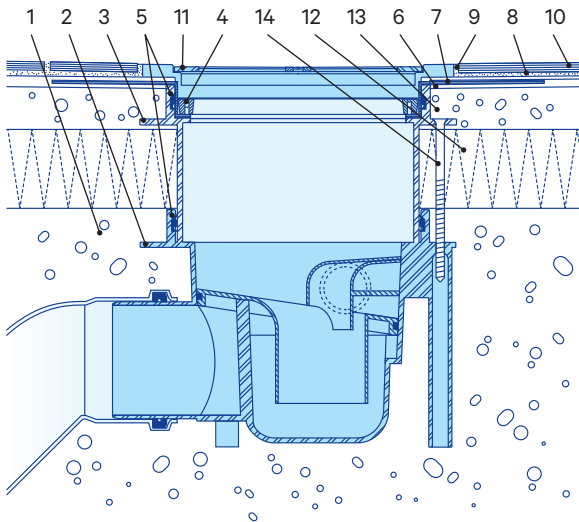

**Meriser Oy**  
 Kauppatie 2, 29900 Merikarvia  
 tel. +358 (0)207 189 810  
 www.merika.fi, merika@meriser.fi



Quality for HVAC  
 Technology

