

Installation instructions for Merika® build-up ring UMK-K

Merika no. 4011



- **Size: 150 × 100**
- **Weight/kg: 0,296**
- **HVAC no: 3311431**
- For vinyl floor and tile installation
- For wooden and concrete floors
- 2 pcs ø40 sideoutlet
- The delivery includes 3 screws

- **Note!** The build-up ring must be cut straight. The build-up ring is lubricated with a lubricant and pressed to its place.
- Note in the installation that the screws of the build-up ring (3 pcs) are screwed to their places but **not tightened**. The screws do not need to be tightened as the sealing is in the over sheath of the build-up ring/floor drain. Tightening the screws will deform the floor drain/build-up ring.
- If necessary, the side connections are opened by hitting them open with a punching tool.

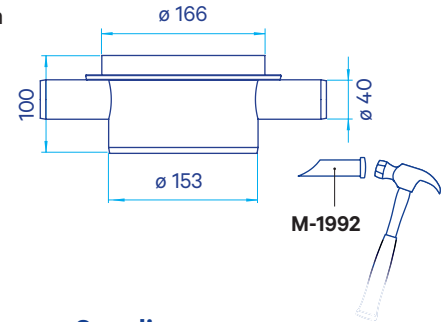

Supplies:

M-1992 Special opening tool
HVAC no. 3311425

Spare parts:

M-202_03 Lip seal for a floor drain, new 160



Meriser Oy

Kauppatie 2, 29900 Merikarvia
Finland

tel. +358 207 189 810

www.merika.fi, merika@meriser.fi

In addition to this guide, the decrees 782/2017 on Humidity control performance and 63/2023 on Water supply and sewerage equipment of properties given by the Ministry of the Environment shall be followed.

The installation work must always be made by a HVAC professional. We follow the terms of the Association of Technical Traders.



Quality for HVAC
Technology

