

# Installation instructions for Merika® build-up ring



## Merika no. 401



- Size: 150 × 100
- Weight/kg: 0,296
- HVAC no: 3318110
- For vinyl floor and tile installation
- For wooden and concrete floors
- 2 pcs ø32 side connections
- The delivery includes 3 screws

- Note! The build-up ring must be cut straight.
- The build-up ring is lubricated with a lubricant and pressed to its place.
- Note in the installation that the screws of the build-up ring (3 pcs) are screwed to their places but **not tightened**. The screws do not need to be tightened as the sealing is in the over sheath of the build-up ring/floor drain. Tightening the screws will deform the floor drain/build-up ring.
- If necessary, the side connections can be opened by hitting them open with an opening tool.

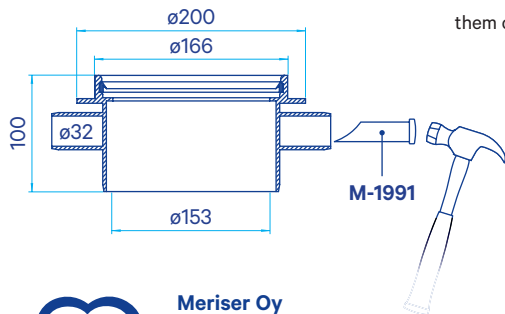

### Practical screw fastening to a floor drain



#### Accessories:

- M-401** Build-up ring, HVAC no: 3318110
- M-1991** Opening tool, HVAC-no: 3311417

#### Spare parts:

- M-202\_03** Lip seal for a floor drain, new 160



**Meriser Oy**  
Kauppatie 2, 29900 Merikarvia  
tel. +358 (0)207 189 810  
www.merika.fi, merika@meriser.fi

In addition to this guide, the decrees 782/2017 on Humidity control performance and 814/2020 on Water supply and sewerage equipment of properties given by the Ministry of the Environment shall be followed.

The installation work must always be made by a HVAC professional. We follow the terms of the Association of Finnish Technical Traders.

Quality for HVAC  
Technology

